

ARI-Condensate recovery and return station

Volume: 150-2000 liter

**ARI-CORsys®-St**  
Condensate recovery and return station  
Standard design

- Ready for operation condensate recovery and return station with zinc coated receiver made of S235JRG2 (St37)
- Pump made of EN-JL1030 / 1.4301
- Valves optionally made of:  
EN-JL1040  
EN-JS1049  
1.0619+N

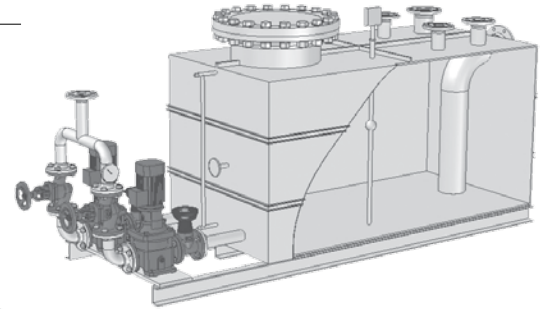
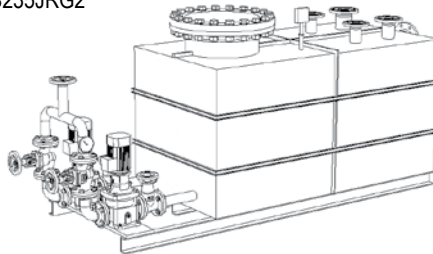

**ARI-CORsys®-SSt**  
Condensate recovery and return station  
Standard design made of stainless steel

- Ready for operation condensate recovery and return station with receiver made of 1.4541
- Pump made of 1.4401
- Valves optionally made of:  
1.4408

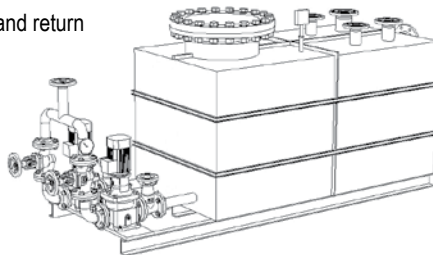

**Features:**

- Process security through harmonized individual components
- Protection against running dry and high water
- Redundant pump protection (two pumps)
- Fixed liquid levels
- High-quality corrosion protection through stainless steel possible
- Supplied ready for installation
- Service through plant documentation
- Low-NPSH-Pumps

## ARI-CORsys® Condensate recovery and return station

ARI-CORsys®-St Standard design

ARI-CORsys®-SSt Standard design made of stainless steel

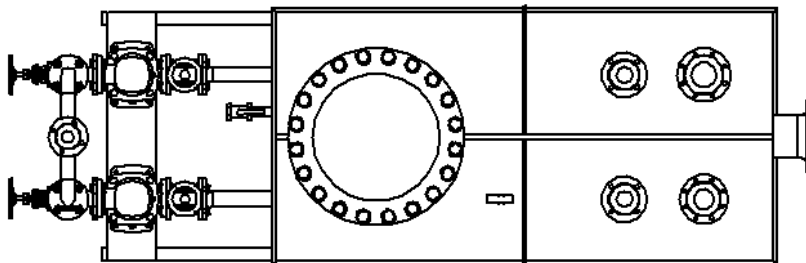
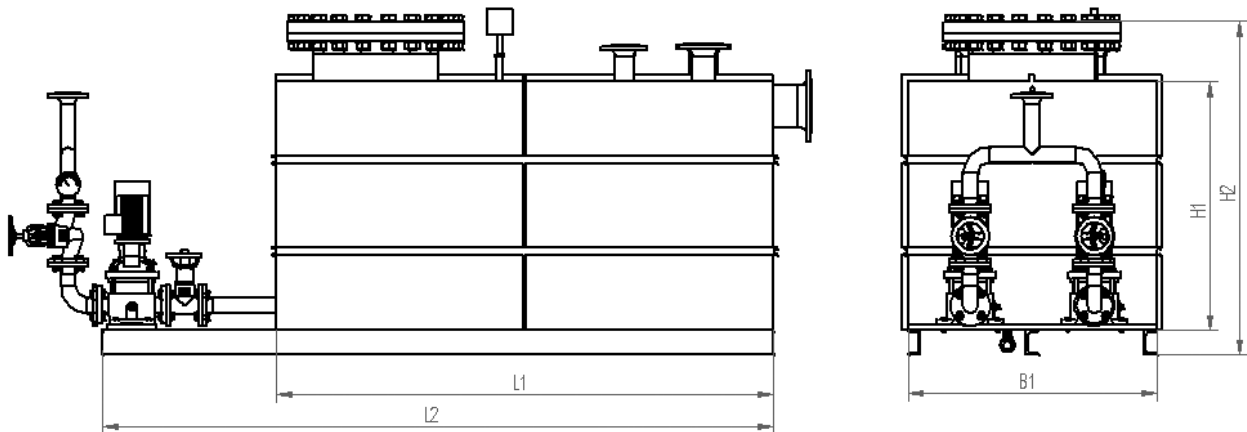
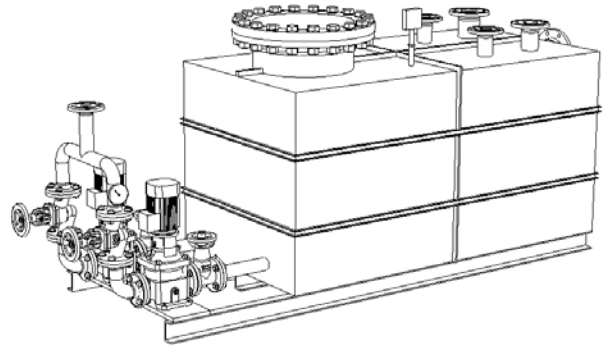

(Example version)

### Dimension and weights

Typ	Volume	L1	L2	H1	H2	B1	Weight
	(Ltr.)	(mm)	(mm)	(mm)	(mm)	(mm)	(kg)

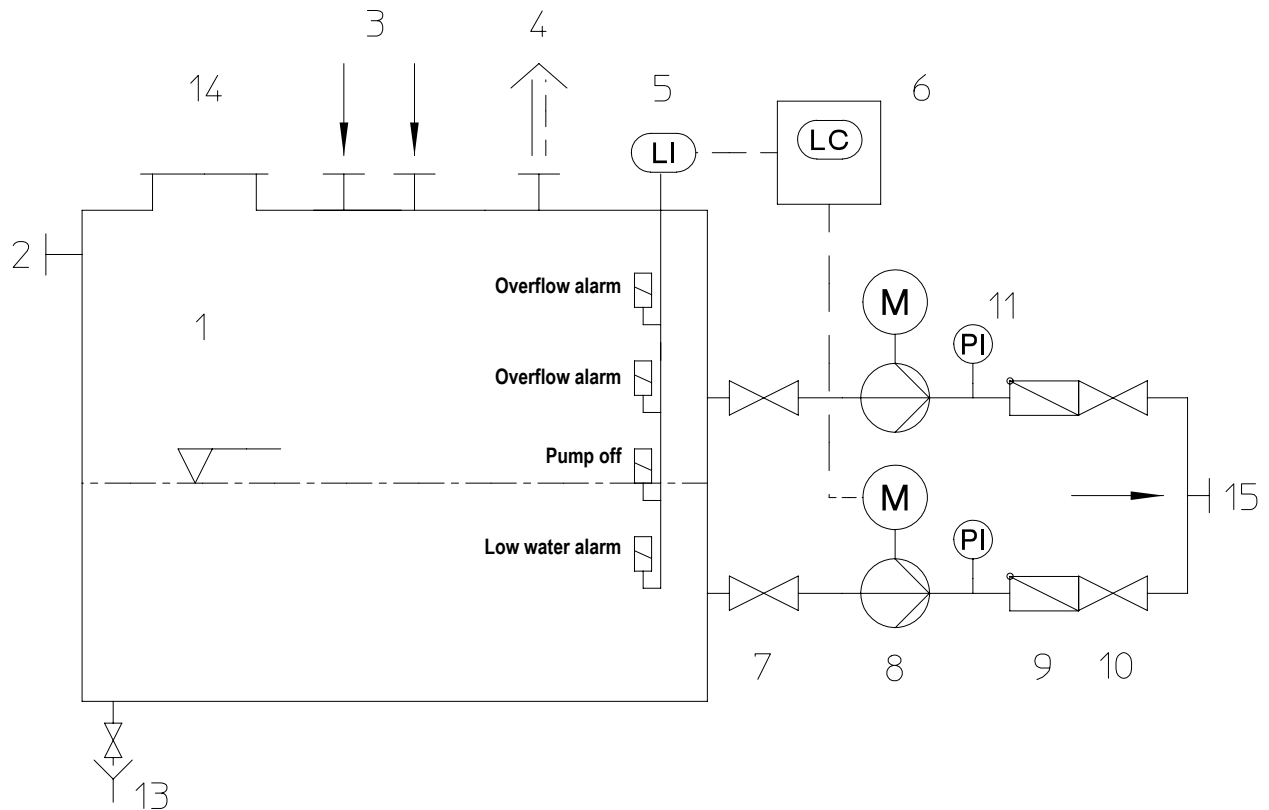

Pos.	Description	Material			
		PN16 - 12.CRS	PN16 - 22.CRS	PN16 - 32.CRS	PN16 - 52.CRS
1	Receiver	S235JRG2, 1.0038 / P250GH, 1.0460			X5CrNi18-10, 1.4301
2	Overflow (to the outside)	P235TR2, 1.0255 / P250GH, 1.0460			X6CrNiTi18-10, 1.4541
3	Condensate feed (the number of receiver connections varies in accordance with the size of the receiver)				
4	Vapour pipe connection (vent to the outside)				
5	Level measuring	Sst / Polymer			SSt / Polymer
6	Liquid level controller	Al / Polymer-Gehäuse			
7	Stop valve, Suction side (ARI EURO-WEDI)	EN-JL1040, EN-GJL-250			GX5CrNiMo19-11-2, 1.4408
8	Low-NPSH-pump	EN-JL1030, EN-GJL-200 / X5CrNi18-10, 1.4301	EN-JS1050, EN-GJS-500-7 / X5CrNi18-10, 1.4301		X5CrNiMo17-12-2, 1.4401
9/10	Stop valve, Pressure side ARI-STOBU with non-return function (LK+F)	EN-JL1040, EN-GJL-250	EN-JS1049, EN-GJS-400-18U-LT	GP240GH+N, 1.0619+N	GX5CrNiMo19-11-2, 1.4408
11	Pressure gauge, complete	St / SSt			
13	Drain to the outside	St / SSt			
14	Inspection opening	P235TR2, 1.0255 / P250GH, 1.0460			X6CrNiTi18-10, 1.4541
15	Outlet				
	Pipes / flanges				

Information / restrictions in the technical rules must be observed!

Permissible operating temperature 95 °C, receiver pressure atmospheric, pump pressure side max. pressure load, see delivery head diagram..

**Application**

The ARI condensate recovery and return station is used in steam systems and serves to return the accruing condensate for reuse. The condensate pumps that are used remove the condensate from the receiver and transport it back to the boiler installation.

The station is a compact installation premounted on a base frame and consists of high-quality individual components. An On/Off water level control with a safety switch for dry unning and high water protection guarantees safe operations. The pump's output is controlled in dependence on the level in the receiver. Recirculation protection is ensured through the installation of check valves. The strainers that are fitted provide additional security.

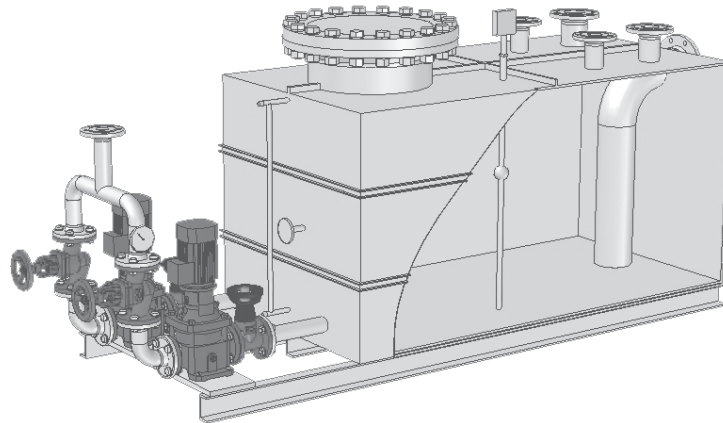

Example version

PED 2014/68/EU, MD 98/37/EC, EMC 89/336/EEC, LVD 73/23/EEC

**Evaluation in accordance with PED 2014/68/EU (Fluid Group 2)**

The evaluation of an installation (assembly of pressure vessels) is aligned to the correspondingly highest category of an installation component 2. Art. 10 Paragraph 2. If all the individual components of a subassembly fall under Art. 3.3 (sound engineering practice), the installation may not display a CE mark in accordance with PED. If the subassembly falls to the maximum under Category I and under Article 1, Paragraph 3.6, the subassembly does not fall under the Pressure Equipment Directive.

**Declaration of conformity/manufacturer's declaration:** See the last page in the current operating instructions for the above-mentioned EC Directives.

**Operating instructions can be ordered by phone (+49 52 07) 994-0 or fax (+49 52 07) 994-158 or 159.**

**Ausführungen**

Code	Design	Type	
		CRS-St	CRS-SSt
A	Without controller Receiver only with fittings and pumps	O	O
B	Level electrode + pump controller Completely wired with the switchgear cabinet	O	O
C	Inspection glass liquid level indicator + electromagnetic switch Completely wired with switchgear cabinet	O	O
D	Controller assembly kit Level electrode premounted and enclosed with pump controller	O	O
E	Controller assembly kit Inspection glass liquid level indicator + electromagnetic switch premounted	O	O
J	Receiver made of S235JRG2 (St37) zinc coated	X	
K	Receiver material 1.4301		X
L	Receiver material 1.4571		O
M	Receiver non insulated	X	X
O	Receiver insulated via factory	O	O
P	Receiver with insulation bracket	O	O
S	One Low NPSH pump (single)	O	O
T	Two Low NPSH pumps (twin)	X	X

X = Standard design / O = Special design

Receiver volume = 1/4 to 1/3 of the accruing condensate volume  
 Pump output = 2 to 3 times the accruing condensate volume

**System code:**

**Type** ARI-32.CRS-R (PN16 standard)  
 ARI-52.CRS-R (PN16 stainless steel)  
**Type of pump** CR3 - 15 Low NPSH-Pumpe (see diagram on page 6-7)  
**Special design** Code A to T (see page 4)

**Example:**

Condensate volume 2700 liter/h, Delivery head 20 m, Receiver material stainless steel 1.4571, two pumps

**Type 52 - CRS-R 10 - T - L** Condensate recovery and return station ... ..  
 - Type 52-CRS-R 10 (receiver volume 1000 litres)  
 - Receiver made of material 1.4571 (Code G see page 4)  
 - Two pumps (Code T see page 4)  
 - Low NPSH pump CR5-5, 6.5 m³/h, 20 m delivery head (see page 6)

**Please indicate when ordering:**

1. **ARI-CORsys®** **Type** \_\_\_\_\_  
 z.B. Type 52 - CRS-R10 - T - L
2. Condensate volume \_\_\_\_\_ (m³/h)
3. Pump delivery head \_\_\_\_\_ (m)
4. Connection Feed DN \_\_\_\_\_, number \_\_\_\_\_; Vapour pipe PN16 DN \_\_\_\_\_; Overflow PN16 DN \_\_\_\_\_;  
 Pressure side (outlet) PN16 DN \_\_\_\_\_
5. Receiver volume \_\_\_\_\_ (l)
6. Receiver shape  round lying
7. Pump design \_\_\_\_\_ see diagram, output curve
8. Length of vapour pipe \_\_\_\_\_ (m)
9. Power supply for pump \_\_\_\_\_ (V), \_\_\_\_\_ (Hz), protection class \_\_\_\_\_ (standard IP54)
10. Dimension of installation location (if known) \_\_\_\_\_ (m) / \_\_\_\_\_ (m) / \_\_\_\_\_ (m)  
 (clearance to wall or room dimensions)
11. Design deviation from standard \_\_\_\_\_ Code A to P (see page 4)
12. Material
 

Low-NPSH-pump	<input type="checkbox"/> EN-JL1030/1.4301 (GG/stainless steel)
	<input type="checkbox"/> EN-JS1050/1.4301 (GGG/stainless steel)
	<input type="checkbox"/> 1.4401 (stainless steel)
Valves	<input type="checkbox"/> EN-JL1040
	<input type="checkbox"/> EN-JL1049
	<input type="checkbox"/> 1.4408

Diagram Low-NPSH CR5

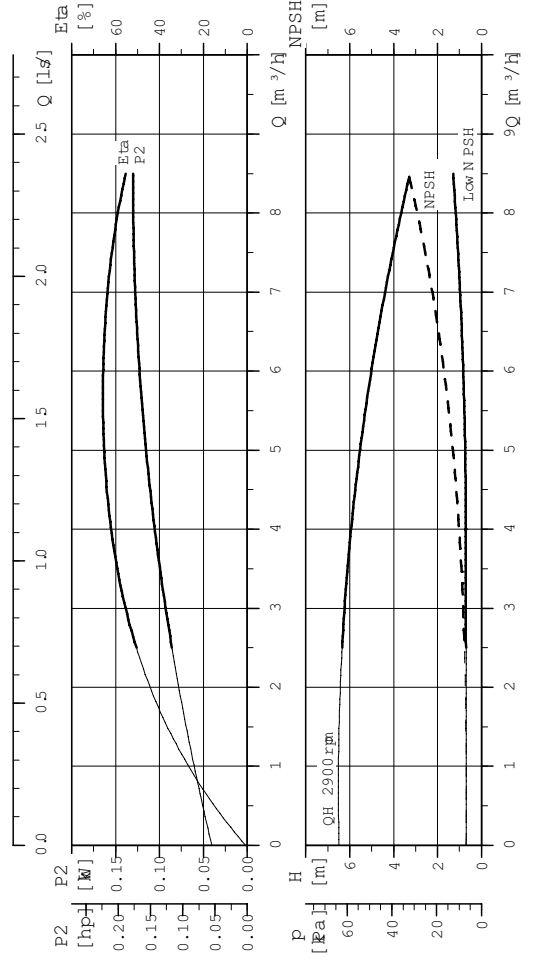
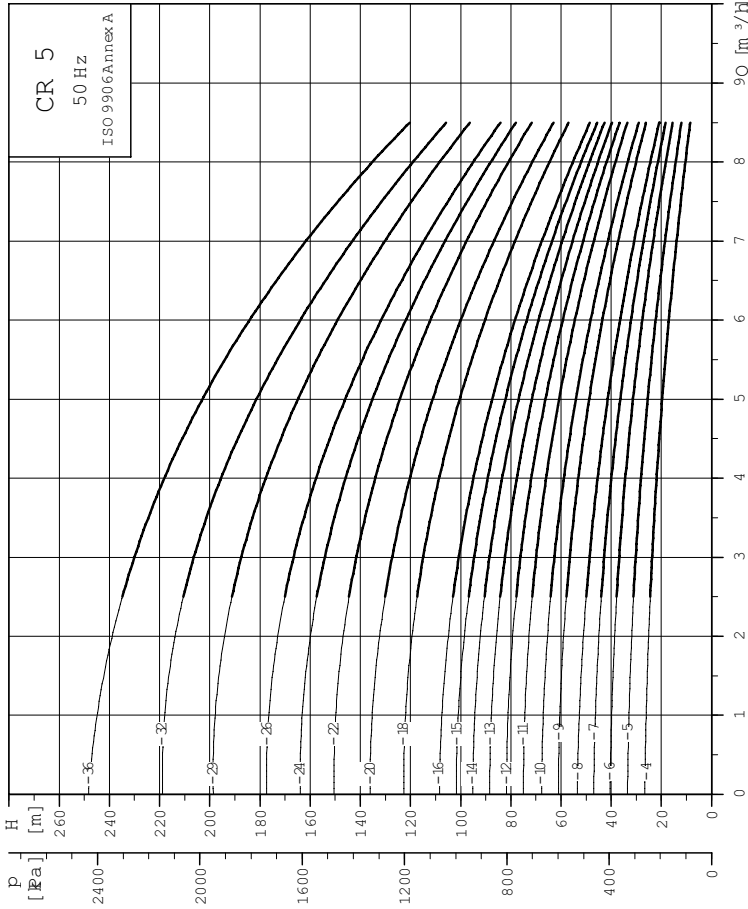

Diagram Low-NPSH CR3

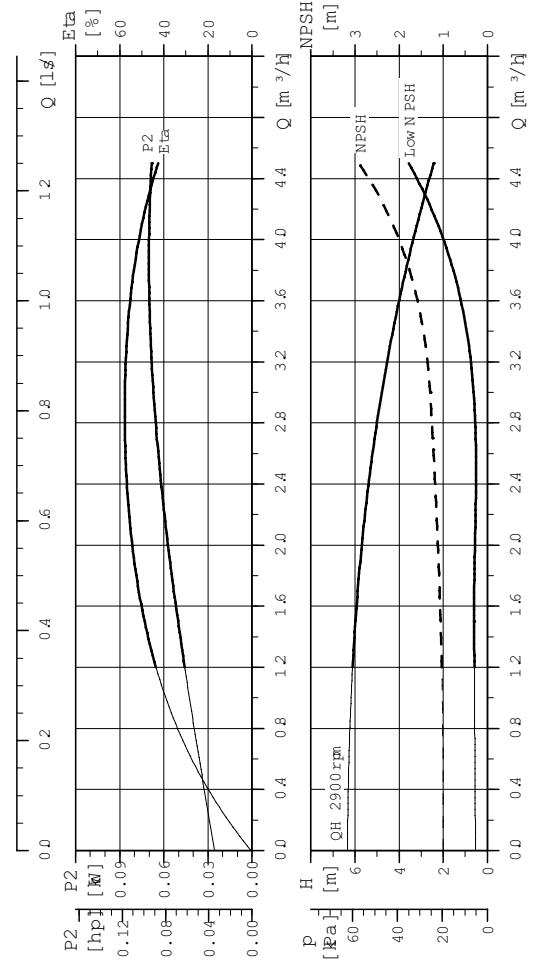
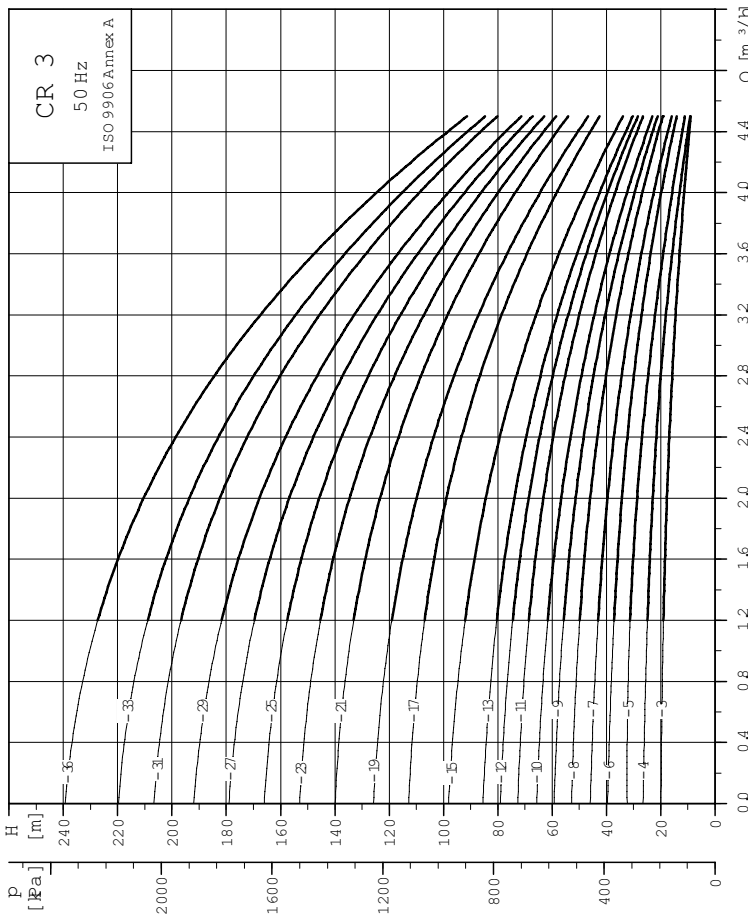

Diagram Low-NPSH CR10

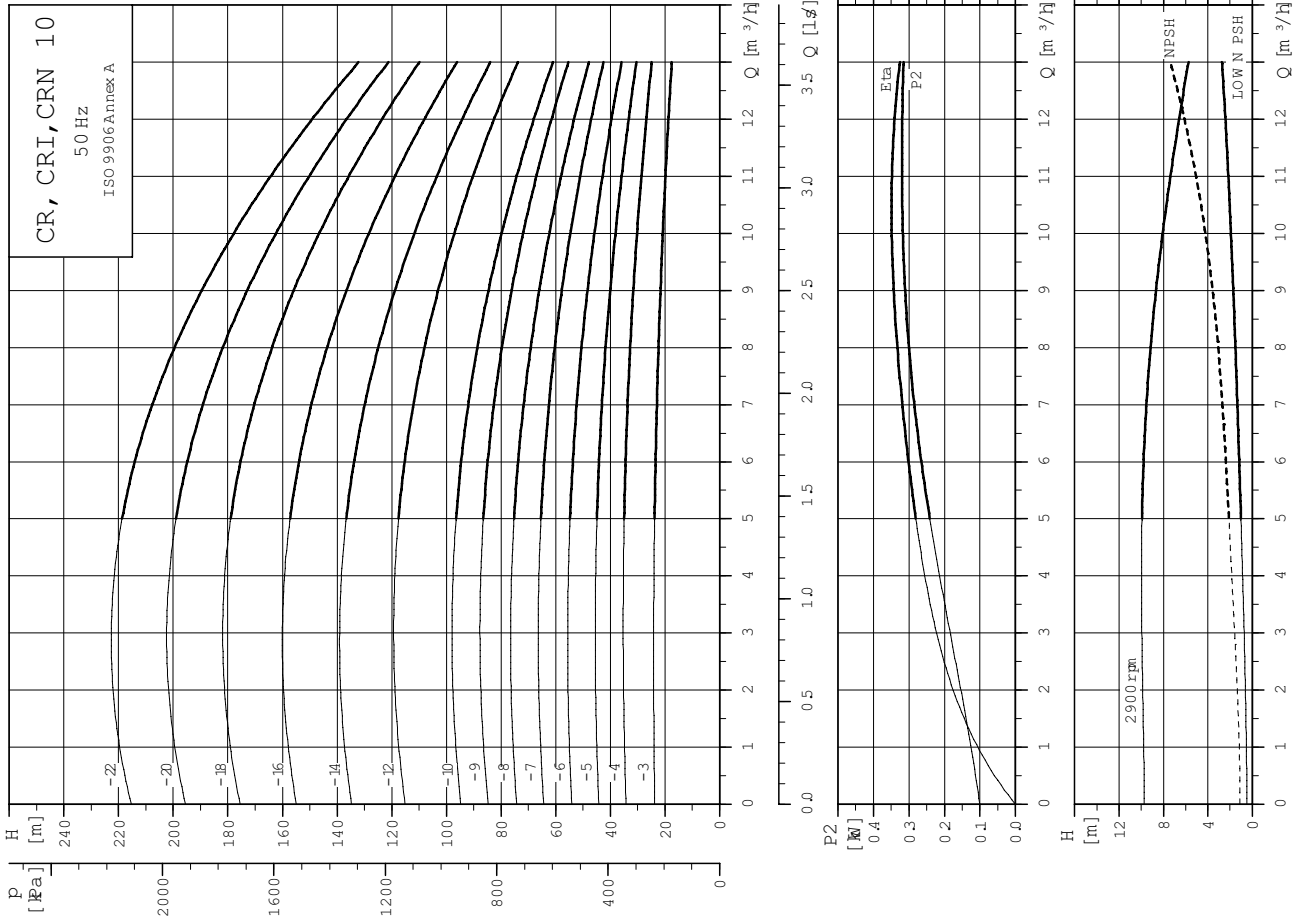
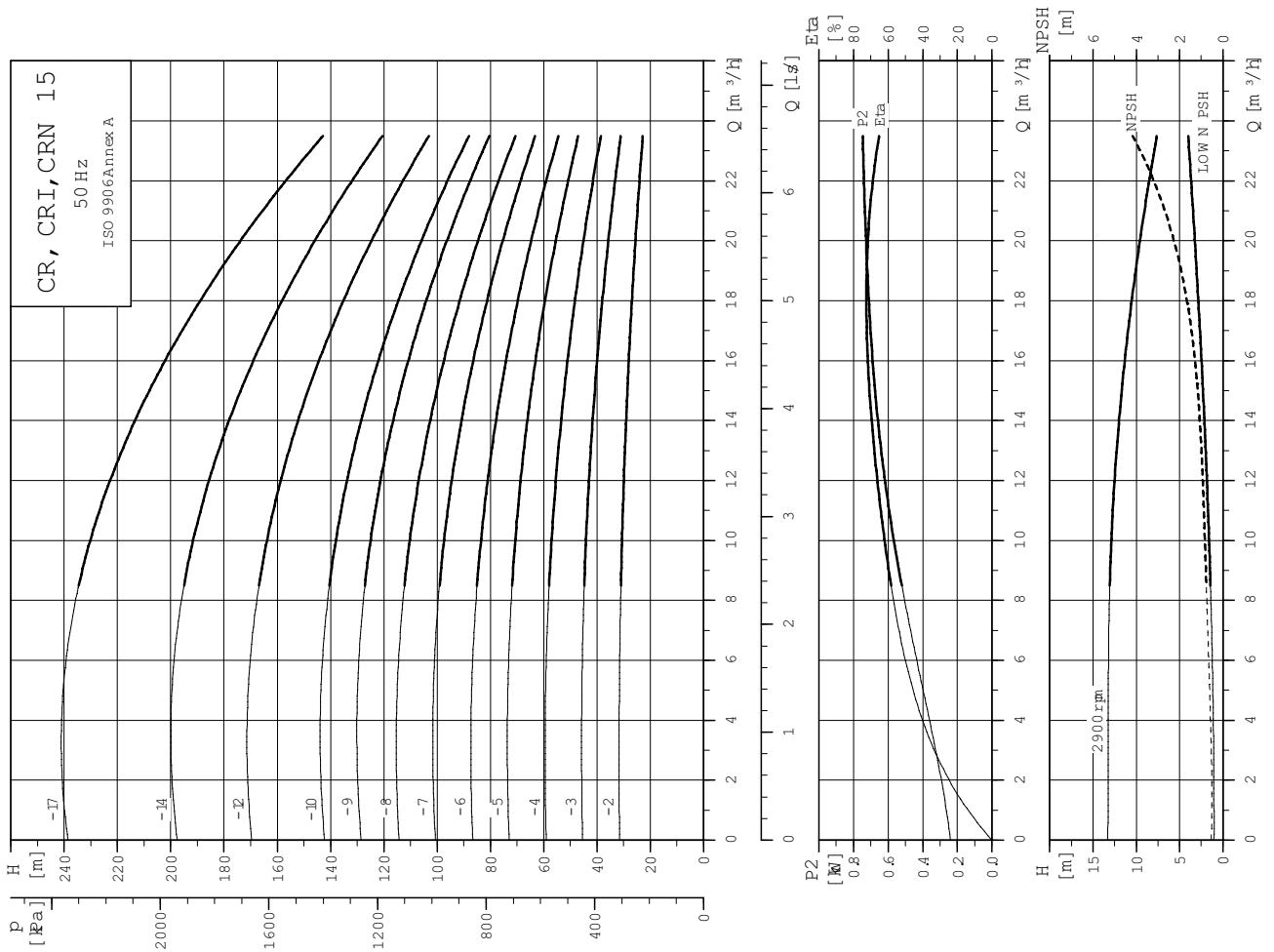

Diagram Low-NPSH CR15





**Technik mit Zukunft.**  
DEUTSCHE QUALITÄTSARMATUREN

ARI-Armaturen Albert Richter GmbH & Co. KG, D-33756 Schloß Holte-Stukenbrock,  
Tel. +49 (0)5207 / 994-0, Telefax +49 (0)5207 / 994-297 oder 298 Internet: <http://www.ari-armaturen.com> E-mail: [info.vertrieb@ari-armaturen.com](mailto:info.vertrieb@ari-armaturen.com)